

X30-xx-150-x Technical Specification

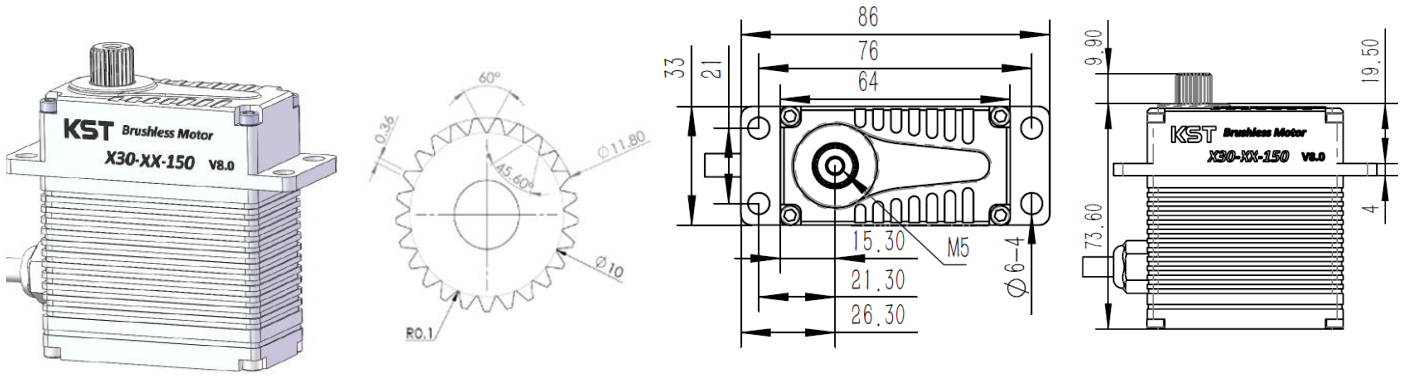

Output Shaft Spline (25T&12mm)

1. Servo Data

	X30-12-150-x	X30-15-150-x	X30-28-150-x
Rated Voltage	DC12.0V	DC15.0V	DC28.0V
Voltage Range	DC8.4V-12V	DC14V-16V	DC24V-30V
Torque	105Kgf.cm@8.4V	180Kgf.cm@15V	150Kgf.cm@24V
	150Kgf.cm@12V		165Kgf.cm@28V
Speed	0.25sec/60°@8.4V	0.15sec/60°@15V	0.20sec/60°@24V
	0.17sec/60°@12V		0.18sec/60°@28V
Working Frequency	1520us/333Hz		
Default Travel Angle	±50°=100° Total		
Temperature Range	-20°C.....+65°C		
Soft Start	Programmable		
Programmable	Yes		
Case Material	Aluminum Alloy		
Motor Type	Brushless DC Motor		
Gear Set Material	Hardened Steel		
Position Sensor	Potentiometer		
Ball Bearing	6BB		
Case Dimensions	64mm*33mm*74mm±0.2mm		
Weight	360g±10%		

2. Performance

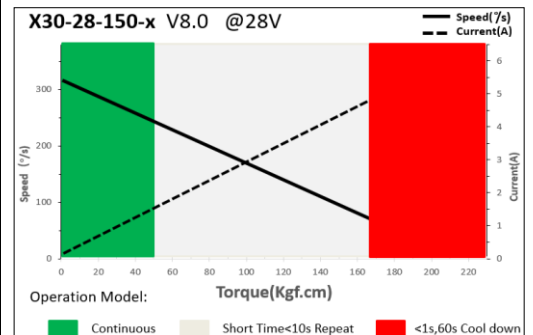
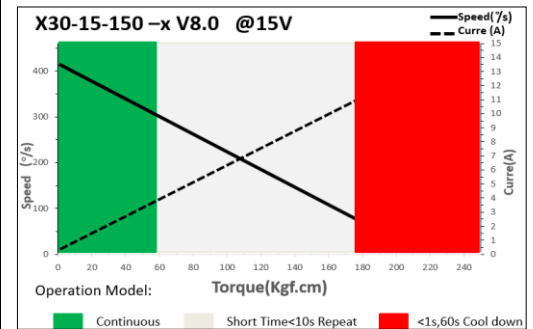
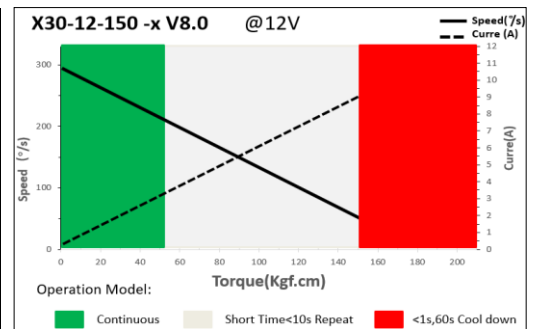

3. Command signal

3.1. PWM Command Interface

Signal Voltage	HIGH: min.3.3V, max.5.0V Low: min.0.0V, max.1.5V
Pulse Lengths	900us-2100us
Pulse Lengths for Position	1000us/1500us/2000us -50°/0°/+50°

3.2. RS485 Command Interface

Baud-Rate	115200 ±1.5% bits/s
Protocol	10 Byte (incl. 1 byte Check Sum)
(Documentation)	8
Number of Data	1
Number of Stop	None

Command / Response Frame			
Byte #	Description	Byte #	Description
1	Frame Head(0xFE)	6	Data
2	Version(0xCA)	7	Data
3	Address	8	Data
4	Command code	9	Check Sum
5	Data	10	(0A) Frame End

3.3 CAN Bus Command Interface

Baud-Rate	Default value 500Kbps	Communication	CAN Open standard frame CAN Extended frame
Node number	0 x25 (range 1 ~ 127, 0 is radio)		

3.4. Feedback Signal

3.4.1 Position Feedback Signal (PWM Versions)

The Position Feedback signal is an output signal with a square wave which is directly related to the output shaft's angular position. Reference is Supply Ground.

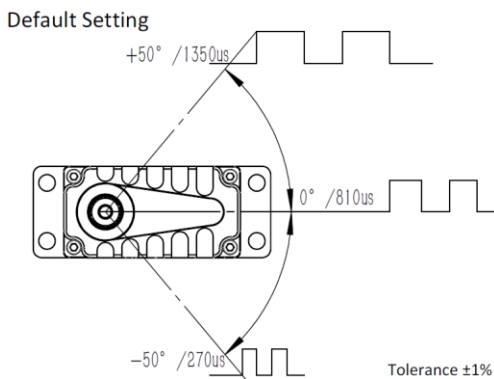

Position Feedback

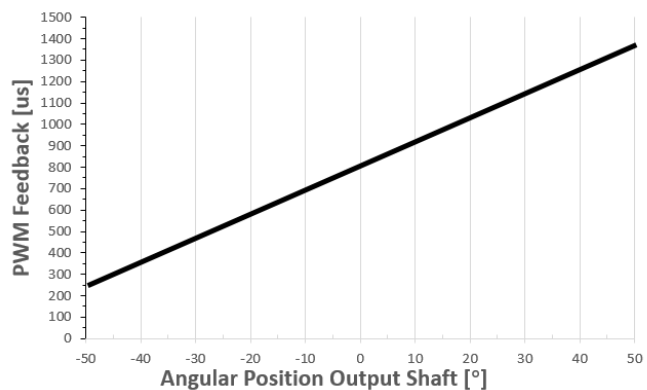

3.4.2 Feedback Value (Bus Version)

Integrated in the Bus protocol a Feedback Value, including the Angle position, Temperature, current value. Value read by sending request command. Provide the details of the bus in the document.

4. Electrical Connection

Pin	Assignment PWM		Assignment RS485 BUS		Assignment CAN BUS	
	Pin	Description	Pin	Description	Pin	Description
1	1	DC+ Supply Voltage	1	DC+ Supply Voltage	1	DC+ Supply Voltage
2	2	DC- Supply Ground	2	DC- Supply Ground	2	DC- Supply Ground
3	3	PWM Signal	3	RS485B	3	CAN_L
4	4	Signal Ground	4	RS485A	4	CAN_H

Note: X30-12-150-“x” ,x1-PWM. x2- RS485. x3.1- CANBUS Standard Frame. x3.2- CANBUS Extended Frame