

# ZOHD

## DART 250G

### User Guide

Thank you for supporting us  
buying a Dart 250G

Stay connected with us through our social media channels:



Contact us: [info@sonicmodell.com](mailto:info@sonicmodell.com) [sales@sonicmodell.com](mailto:sales@sonicmodell.com)

Customer service: [cs@sonicmodell.com](mailto:cs@sonicmodell.com)

[www.sonicmodell.com](http://www.sonicmodell.com)

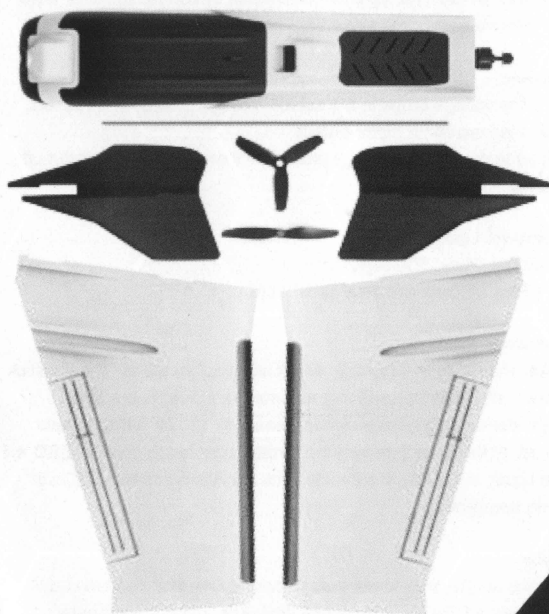

1. Attach the vertical fins with the provided double-side tape.

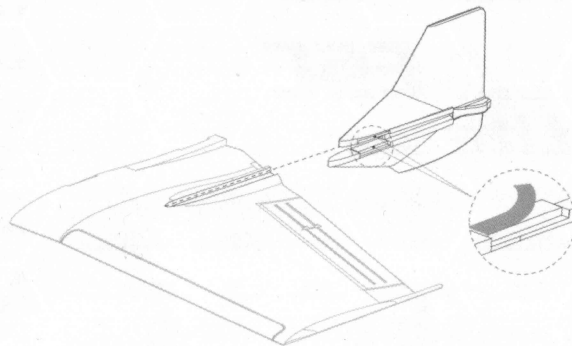

2. Secure the wings with the provided double-side tape. Remember to first run the main spar through the fuselage.

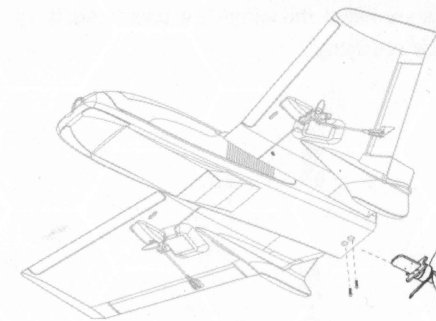
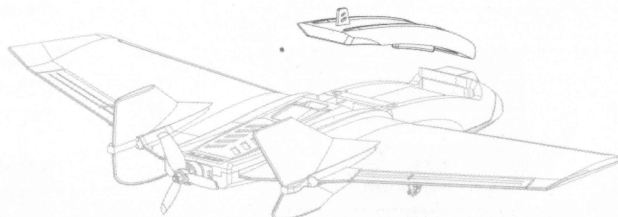
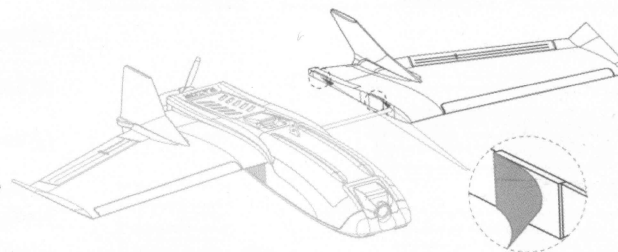

Recommended  
GPS placement

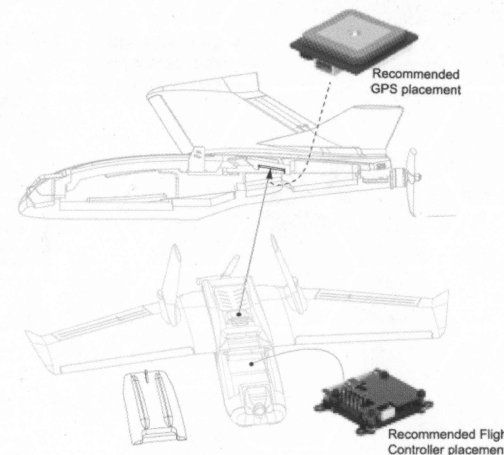

Recommended Flight  
Controller placement

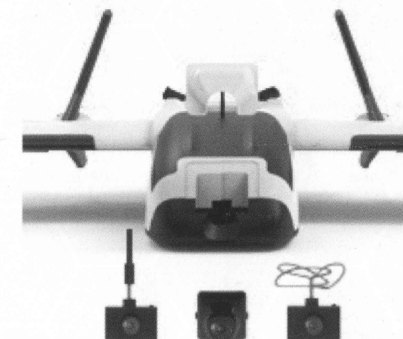

**KIT** Includes only airframe. (Motor, ESC, Servos, Propeller, ZOHD VC400 Camera, ZOHD Kopilot Lite, Battery, Radio controller, Charger are not included.)

**PNP** Includes Motor, ESC, Servos, Propeller. (ZOHD VC400 Camera, ZOHD KOPILOT, VTX, Battery, Radio controller, Charger are not included.)

**FPV READY** Includes Motor, ESC, Servos, Propeller, ZOHD VC400 Camera, ZOHD Kopilot Lite. (Battery, Radio controller, Charger are not included.)

# ZOHD

Inspiring The Future

3. CG marks are below the wings. Be sure to set it properly before flying.

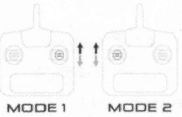
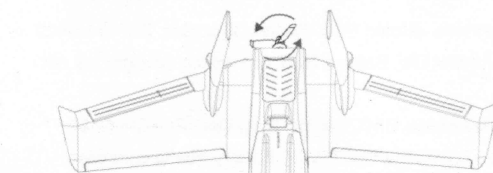
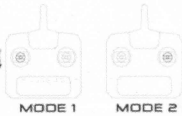
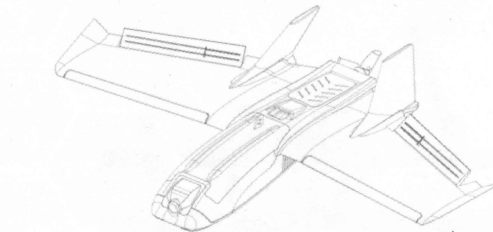
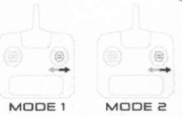
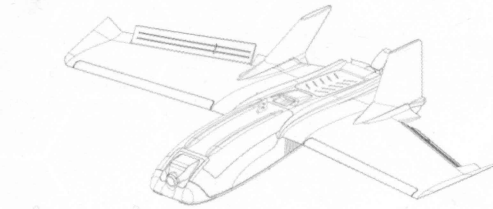
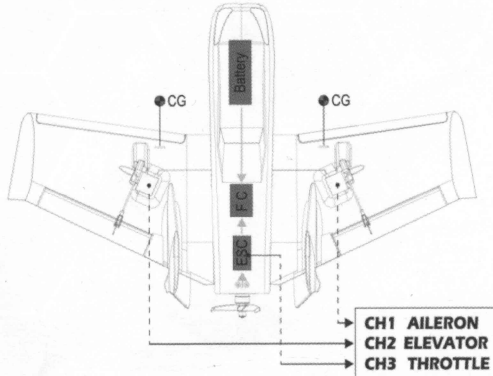

# ZOH D

## 30A ESC

### Lite SERIES

#### 01 Specifications

Model	Con. Current (Good heat dissipation)	Burst Current (Good heat dissipation)	BEC	LiPo	Weight (For reference)	Size (For reference)
ZOH D Lite 30A	30A	40A	S.5V / 2A	2-4S	12g	39x15.5x6.5mm

#### 02 Operation instruction

##### 1. Normal start-up

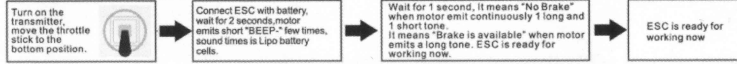

##### 2. Throttle Range calibration

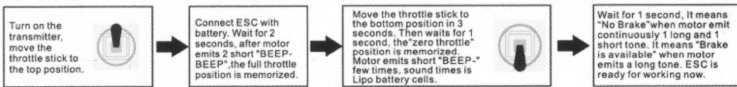

##### 3. Programming

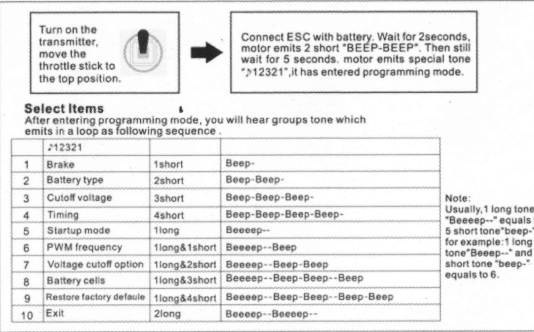

**Select Items**  
After entering programming mode, you will hear groups tone which emits in a loop as following sequence.

Item	1	2	3	4	5	6	7	8
1. Brake	1short	2short	3short	4short	1long	1long&1short	1long&2short	1long&3short
2. Battery type	1short	2short	3short	4short	1long	1long&1short	1long&2short	1long&3short
3. Cutoff voltage	1short	2short	3short	4short	1long	1long&1short	1long&2short	1long&3short
4. Timing	1short	2short	3short	4short	1long	1long&1short	1long&2short	1long&3short
5. Startup mode	1long	2short	3short	4short	1long	1long&1short	1long&2short	1long&3short
6. PWM frequency	1long&1short	2short	3short	4short	1long	1long&1short	1long&2short	1long&3short
7. Voltage cutoff option	1long&2short	2short	3short	4short	1long	1long&1short	1long&2short	1long&3short
8. Battery cells	1long&3short	2short	3short	4short	1long	1long&1short	1long&2short	1long&3short
9. Restore factory default	1long&4short	2short	3short	4short	1long	1long&1short	1long&2short	1long&3short
10. Exit	2long	2short	3short	4short	1long	1long&1short	1long&2short	1long&3short

Note: Usually, 1 long tone "Beeep--" equals to 5 short tone "beep-", for example: 1 long tone "Beeep--" and 1 short tone "beep-" equals to 6.

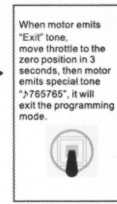

##### Item parameter

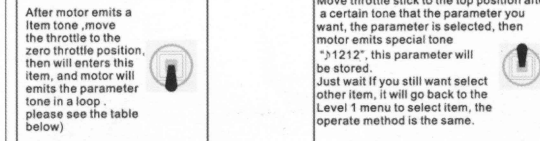

Item	Prompt tone							
	1short	2short	3short	4short	1long	1long&1short	1long&2short	1long&3short
1. Brake	NO	Soft	Heavy	Very Heavy				
2. Battery type	LiPo	NiCb/NiMh						
3. Cutoff voltage	2.8V	3.0V	3.2V					
4. Timing	0°	3.75°	7.5°	11.25°	15°	18.75°	22.5°	26.25°
5. Startup mode	Normal	Soft	Very Soft					
6. PWM frequency	12KHz	8KHz						
7. Voltage cutoff option	Reduce cutoff	Cut off						
8. Battery cells	Auto	2S	3S	4S				

\*Shadow parts are factory default value

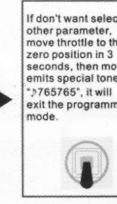

#### 03 Programming parameter

**1. Brake:** [1]NO(default) [2]Soft [3]Heavy [4]Very heavy

**2. Battery type:** [1] LiPo(default) [2] NiCb/NiMh

**3. Cutoff voltage:** Low-voltage protection threshold, [1] Low [2] Medium (default) [3]High For Ni-xx battery packs: Low/Medium/High cut off voltage is 50%/65%/75% of the battery packs initial voltage For LiPo battery: can count battery cells automatic. Low voltage protection threshold :Low (2.8V) /Medium (3.0V) /High(3.2V) . Eg:For 4S/14.8V Lipo battery packs, low voltage protection threshold is 11.2V low/12.0V medium /12.8V high

#### 4. Timing:

[1]0" [2]3.75" [3]7.5" [4]11.25" [5]15 (default) [6]18.75 [7]22.5" [8]26.25 Low (013.759/ 11.259/15 / 18.759) --for most inner rotor motors hail(22.5/26.25) --For 6 poles or higher poles outer rotor motors as usual 15 applies to all the outer rotor motors, but for improving efficiency recommend that set low timing for 2 poles motor( most inner rotor motors), set high timing for 6 poles and high poles motors( most outer rotor motors). If need high speed motor, you can set high timing. Some motors should set special timing, if not sure, you'd better to set timing as motor manufacturer recommended ,or set 150.Note: After changing timing, please test on the ground before flying

**5. Startup Mode:** Start up with linear acceleraton

[1] Normal: No latency from 0% throttle to 100% throttle. (default)

[2] Soft: It takes 6 seconds from 0% throttle to 100% throttle.

[3] Very soft: It takes 12 seconds from 0% throttle to 100% throttle.

**6. PWM frequency:** [1]12KHz (default) [2]8KHz

For high poles and high speed motors, the higher PWM frequency can make motor drive smoothly, but the higher PWM frequency will make ESC hotter.

#### 7. Voltage cutoff option:

[1] Reduce cutoff(default): the voltage drops to the set low-voltage protection threshold. ESC will reduce the power then cut off the motor output  
[2] Cut off: the voltage drops to the set low-voltage protection threshold, ESC will cut off the motor output immediately.

**8. Battery cells:** Available for Lipo battery only.

[1] Automatic judgment(default) [2]2S [3]3S [4]4S

You also can select the options according to your battery cells.

#### 9. Restore default settings

When the beeping indicates the mode of "Restore default settings", move the throttle stick to zero position in 5 seconds after the beeping can activate the mode. There is no sub-menu under this mode, the motor makes indication tones of "12321" which means default settings are restored. At this time if moving the throttle stick to top position.ESC will enter programming mode again, if keeping the throttle stick to bottom position.ESC will enter the first programming item(Brake).

#### 10. Exit program mode

After a sound "Beep-" , move throttle stick to the bottom position, enters the item of exit program mode, motor emits sound "765765" the same time, it represents ESC enters normal operation mode.