

INSTRUCTION MANUAL

F959 Sky-king



Specifications

CONTENTS OF THE BOX:

- 1 x RC Airplane
- 1 x 2.4 GHz remote (6x AA-batteries not included)
- 1 x 7,4V 300mAh battery
- 1 x Spare propeller
- 1 x Wingstiffener
- 1 x Charger

SPECIFICATIONS:

- 2.4GHz Airplane
- 1 main engines
- 1 Li-po Battery 7,4V 300mAh
- Height:
- Length: 565 mm
- Width: 750 mm
- Weight: 95g

Safety precautions

- Read the manual carefully and completely
- This model is not suitable for children under 14 years and contains small parts
- Children should only use this model under the supervision of an adult
- Keep hands, face, hair and clothes away from blades.
- Stand out of reach of moving parts of the copter
- After using the copter ALWAYS disconnect the battery and remove it from the device
- The model and the transmitter must be switched off after use
- Always fly in an open and safe environment where you will not cause any danger to others
- For the remote control, we recommend AA batteries with a voltage of 1.5 to 1.2 volts
- For people without experience, we recommend that you learn to fly with an experienced user during your first flights
- Before each flight, test the distance limit of the transmitter
- Keep these instructions safe
- Always follow local laws and regulations! Contact your reseller when in doubt.

DO NOT FLY:

- Around people or animals
- Around large groups of people
- In limited visibility or dark conditions
- Winds above 2 Beaufort
- Near high voltage pylons and / or other types of cabling
- During thunderstorms, rain or high humidity. The device is not water-resistant.

Battery recycling recommendations

For the sensitive and rational conservation, protection and improvement of the quality of the environment, protection of human health and the preservation of natural resources, the user must send an unusable product to relevant facilities created to this purpose in accordance with the law.

The crossed out wheellie bin means that the product must be recycled (WARNING: do not throw it in your bin).



The user must return used batteries and rechargeable batteries. It is forbidden to dispose of used batteries in the bins containing household waste! Batteries / accumulators containing hazardous substances are marked with the crossed out wheellie bin. The symbol indicates that the product should be recycled. The chemical symbols for the respective hazardous substances are Cd (cadmium), Hg (mercury), Pb (lead). The used batteries can be disposed for free of charge at collection points in your community, stores or wherever batteries are sold. You are kindly requested to conform to your legal obligations and contribute to the protection of our environment.

Li-po Battery instructions

- Keep the batteries out of reach of children
- Non-rechargeable batteries should not be recharged
- Unequally charged batteries or different battery types should not be used together
- Use recommended batteries or similar
- After using the product, remove the batteries if you will not use it again for a long period of time
- The terminals must not be short-circuited
- This model is equipped with a rechargeable Li-po Battery. Li-po batteries require special attention, follow the manual
- The batteries must be charged with the charger supplied by WLtoys
- When charging the battery, always ensure that you do so on a non-combustible surface
- Do not leave charging without supervision
- Always charge the battery to 100%
- Ensure that the battery wires are not in contact to avoid a short-circuit
- The ignition wires of the battery must not be modified or damaged
- Never damage the battery mechanically (this could cause an explosion)
- The battery should not be placed near children (unless you have an adult supervision)
- The technical design of the battery must not be changed
- Touching of damaged batteries can cause injury. If there is contact with skin or eyes, seek medical attention immediately!
- Do not charge directly after the flight or when the battery is warm

Battery charging

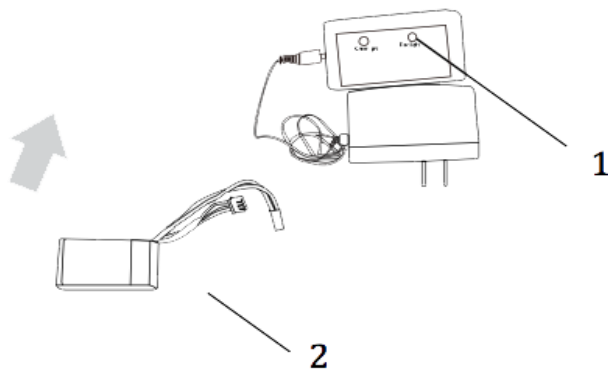

1. LED
2. Li-po Battery

Plug the charger into a wall socket and connect the battery to the charger. This can only be done in one way: by firmly connecting the charging cable. If the green light is on, the battery is fully charged and can be disconnected. Then do not forget to unplug the charger from the wall socket.

Green LED ON = charging battery
 Green LED OFF = charged battery
 Green LED flashing = damaged battery
 Red LED ON = charger
 Red LED OFF = damaged charger / not connected to a wall socket

Input : 220V
 Charging Current : 500mA
 Full Voltage: 4.2 +/- 0.03V

Remote Control / Transmitter

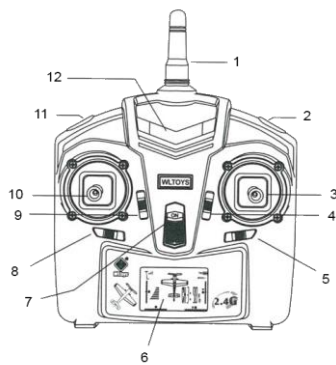

1. Antenna
2. Camera
3. Direction control stick
4. Yaw trim
5. Aileron trim
6. LCD Display
7. Power switch
8. Rotation trim
9. Speed trim
10. Throttle control stick
11. Modes
12. Power LED

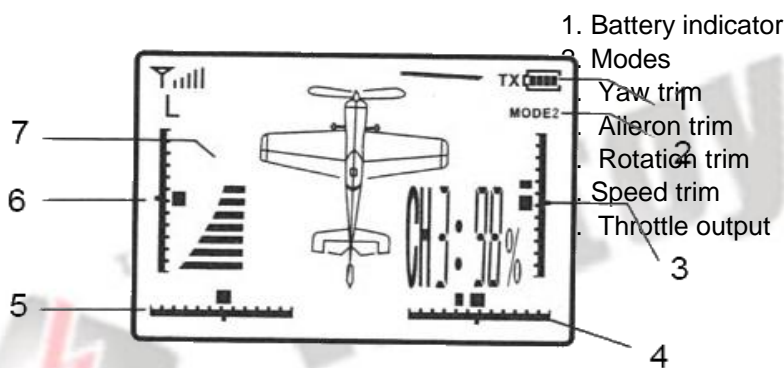

1. Battery indicator
2. Modes
3. Yaw trim
4. Aileron trim
5. Rotation trim
6. Speed trim
7. Throttle output