

INSTRUCTION MANUAL

V913 HELICOPTER BRUSHLESS



Specifications

CONTENTS OF THE BOX:

- 1 x Helicopter
- 1x Remote (4x AA-batteries not included)
- 2x 7.4V 1500mAh Li-po battery
- 1x Charge station
- 2x Tailrotor
- 2x Spare blade

SPECIFICATIONS:

- 4 channels ready to fly helicopter
- 1 Mainmotor, 1 Tailmotor
- Li-po Battery 7,4 Volt 1500mAh accu's
- Height: 85mm
- Length: 690mm
- Width: 110mm
- Weight: 255 gram

Security precautions

- Read the manual carefully and completely
- This model is not suitable for children under 14 years and contains small parts
- Children should only use this model under the supervision of an adult
- Keep hands, face, hair and clothes away from blades.
- Stand out of reach of moving parts of the copter
- After using the copter ALWAYS disconnect the battery and remove it from the device
- The model and the transmitter must be switched off after use
- Always fly in an open and safe environment where you will not cause any danger to others
- For the remote control, we recommend AA batteries with a voltage of 1.5 to 1.2 volts
- For people without experience, we recommend that you learn to fly with an experienced user during your first flights
- Before each flight, test the distance limit of the transmitter
- Keep these instructions safe
- Always follow local laws and regulations! Contact your reseller when in doubt.

DO NOT FLY:

- Around people or animals
- Around large groups of people
- In limited visibility or dark conditions
- Winds above 2 Beaufort
- Near high voltage pylons and / or other types of cabling
- During thunderstorms, rain or high humidity. The device is not water-resistant.

Battery recycling recommendations

For the sensitive and rational conservation, protection and improvement of the quality of the environment, protection of human health and the preservation of natural resources, the user must send an unusable product to relevant facilities created to this purpose in accordance with the law.

The crossed out wheelie bin means that the product must be recycled (WARNING: do not throw it in your bin).



The user must return used batteries and rechargeable batteries. It is forbidden to dispose of used batteries in the bins containing household waste! Batteries / accumulators containing hazardous substances are marked with the crossed out wheelie bin. The symbol indicates that the product should be recycled. The chemical symbols for the respective hazardous substances are Cd (cadmium), Hg (mercury), Pb (lead). The used batteries can be disposed for free of charge at collection points in your community, stores or wherever batteries are sold. You are kindly requested to conform to your legal obligations and contribute to the protection of our environment.

Li-po Battery instructions

- Keep the batteries out of reach of children
- Non-rechargeable batteries should not be recharged
- Unequally charged batteries or different battery types should not be used together
- Use recommended batteries or similar
- After using the copter, remove the batteries if you will not use it again for a long period of time
- The terminals must not be short-circuited
- This model is equipped with a rechargeable Li-po Battery. Li-po batteries require special attention, follow the manual
- The batteries must be charged with the charger supplied by WLtoys
- When charging the battery, always ensure that you do so on a non-combustible surface
- Do not leave charging without supervision
- Always charge the battery to 100%
- Ensure that the battery wires are not in contact to avoid a short-circuit
- The ignition wires of the battery must not be modified or damaged
- Never damage the battery mechanically (this could cause an explosion)
- The battery should not be placed near children (unless you have an adult supervision)
- The technical design of the battery must not be changed
- Touching of damaged batteries can cause injury. If there is contact with skin or eyes, seek medical attention immediately!
- Do not charge directly after the flight or when the battery is warm

Battery charging

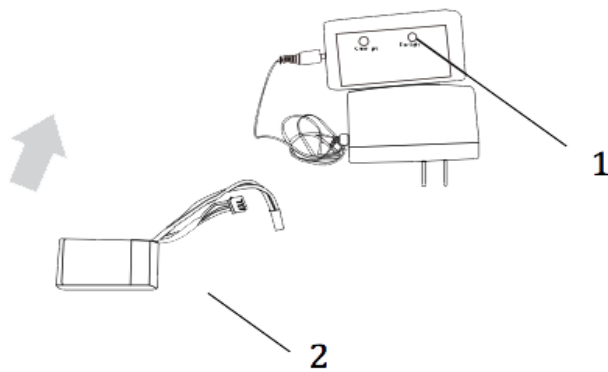

1. LED
2. Li-po Battery

Plug the charger into a wall socket and connect the battery to the charger. This can only be done in one way: by firmly connecting the charging cable. If the green light is on, the battery is fully charged and can be disconnected. Then do not forget to unplug the charger from the wall socket.

Green LED ON = charging battery
 Green LED OFF = charged battery
 Green LED flashing = damaged battery
 Red LED ON = charger
 Red LED OFF = damaged charger / not connected to a wall socket

Input : 220V
 Charging Current : 500mA
 Full Voltage: 4.2 +/- 0.03V

Warning : Always place the battery on a heat resistant surface and never leave it unattended!

Remote Control / Transmitter

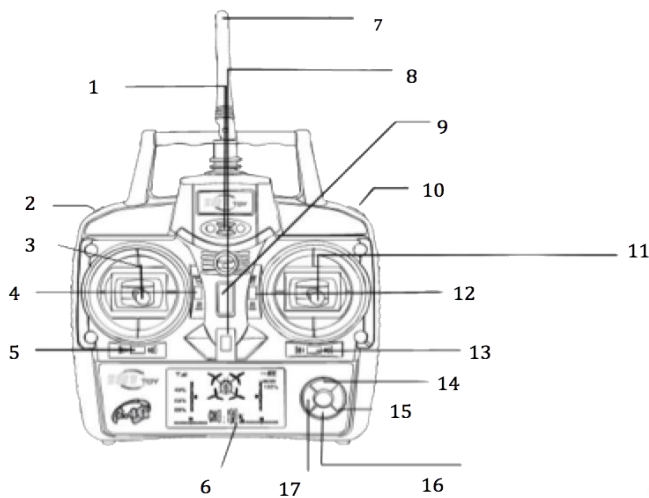

1. Power LED
2. 4 speeds control
3. Gear lever
4. Throttle trim
5. Rotation trim
6. LCD display
7. Antenna
8. Power switch
9. Mode 1 or 3 / Mode 2 or 4 switch (hardware)
10. 360 degree Roll
11. Directional lever
12. Forwards and backwards trim
13. Crab trim
14. Module 1 : Water jet; bubble jet; video; basket up; lead single missile
15. Lighting control
16. Module 2 : Taking photos, running missiles, basket down
17. Mode 1 or 3 / Mode 2 or 4 switch (software)

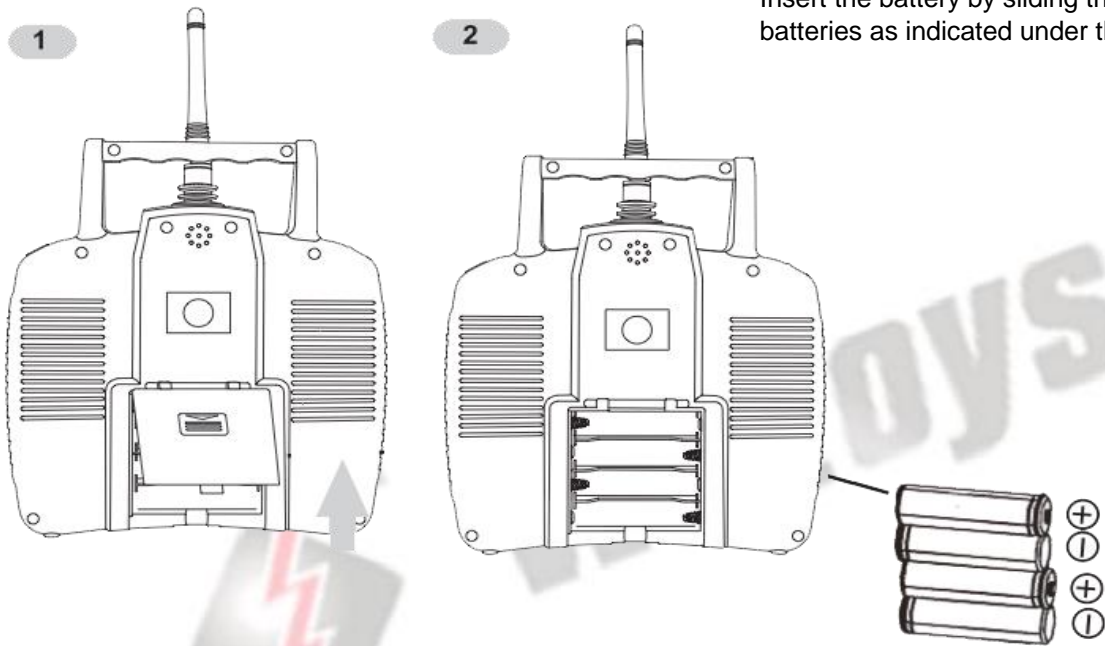

Insert the battery by sliding the cover down. Then insert 4 x AA batteries as indicated under the cover.

How to fly

Flying is really simple, but you need a little practice at first. Connect to www.wltoys.eu to watch educational films.

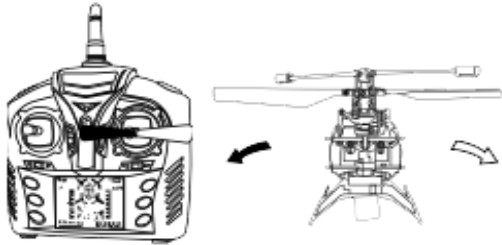

SIDEWARD

The directional lever serves to move the helicopter to the left or the right.

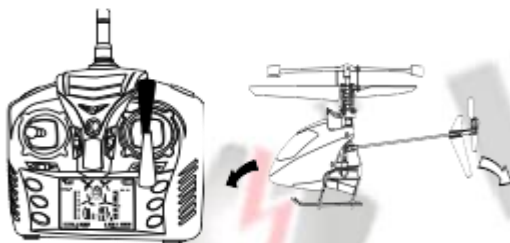

FORWARD

Pushing the directional lever up and down makes your helicopter go forward or backward.

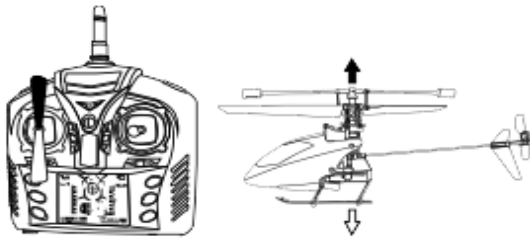

ALTITUDE

Pushing the gear lever up and down makes your altitude rise or fall.

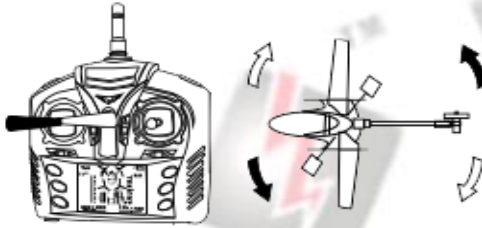

TURN

Pushing the gear lever from side to side, the helicopter will turn on its own axis.

The first flight

1. For your first flight make sure to be with a person experienced in flying copters. We advise you to make your first flights on a relatively soft surface to protect the copter.
2. Find a location away from people, with a smooth surface and without obstacles. Trees, electric lines and water points in the immediate vicinity should be avoided!
3. Place your copter on the ground about 10 feet away from you. Mind that, when you have a quadcopter, the coloured blades indicate the front of the copter. It is easiest to position yourself behind the copter for an easier control.
4. Turn the copter on first. Then turn on the remote control (for some models this will be the other way around). Some models require arming of the motors first. Turn on the copter as well as the controller. then move throttle up and down to connect. after this move throttle to the left low corner and the directional lever to the right lower corner at the same time, hold these down for a few seconds, this will arm the motors.
5. Start the engine and take off to about 1 meter from the ground. In this way you avoid the phenomenon called "ground effect". Near the ground the air currents behave differently than at a higher altitude and this will prevent you from losing control of the copter.
6. Then try to fly gently in one direction. If the engine flies away in the wrong direction, make a controlled landing and try again.

CAUTION

- Ensure that the copter in flight is always within sight and under control.
- Always use a fully charged battery.
- When finished flying, always turn off the copter first, then the remote control.
- Do not use the copter when it has visible or mechanical damage.
- Always fly in an open and Jellyfished environment to avoid dangerous situations.
- Always stay out of reach of rotors.
- Remember to disconnect the battery of the copter after each flight.
- Ensure that you adhere to all the legal requirements that exist for your copter model in the country in which you are using it.
- If you lose control of the copter, disable the propulsion of the engines immediately by pushing the throttle lever down to turn it off.

1. The receiver LED blinks continuously for more than 4 seconds after the helicopter battery have been inserted. No response to the command input. The transmitter is not connected to the device. Repeat the power-on initialization process.
2. No response from the helicopter after the battery have been connected. There is probably contact failure on the battery terminals. Turn on the transmitter and ensure that the battery of the vehicle is correctly inserted. Replace the battery and ensure good contact at the battery's connections. Use fully charged batteries in the remote.
3. The motor does not respond to the throttle stick and the receiver flashes. The helicopter's battery is exhausted. Charge the battery or replace it with a charged battery.
4. The main rotor continues to rotate after landing. Confirm that the gear lever is oriented downward.
5. The main rotor rotates but the device does not take off. The blades may be distorted or the helicopter battery is exhausted. Charge or replace with a fully charged battery and / or replace the blades.
6. The helicopter suffers of strong vibrations. The blades are distorted. Replace the blades.
7. The tail is not balanced after adjusting the clip or speed is inconsistent in the left / right pirouette. Tail rotors are probably damaged. Replace the main wing and / or the main engine.
8. The helicopter was still moving forward after the adjustment of the levers during hover. The gyroscope is not correctly calibrated. The gear lever is placed too high or too low. The boot refines the calibration therefore restart on a flat surface.
9. You can not fly, the helicopter falls. The motor is probably fall out or the gears are loose. Reinstall the motor and tighten the gears.

Spare parts

The copter is not sensitive to crashes, but in case of extreme drops it is possible that some parts may break. All parts can be ordered and easily assembled. Please contact your dealer or visit www.wltoys.eu for more information.

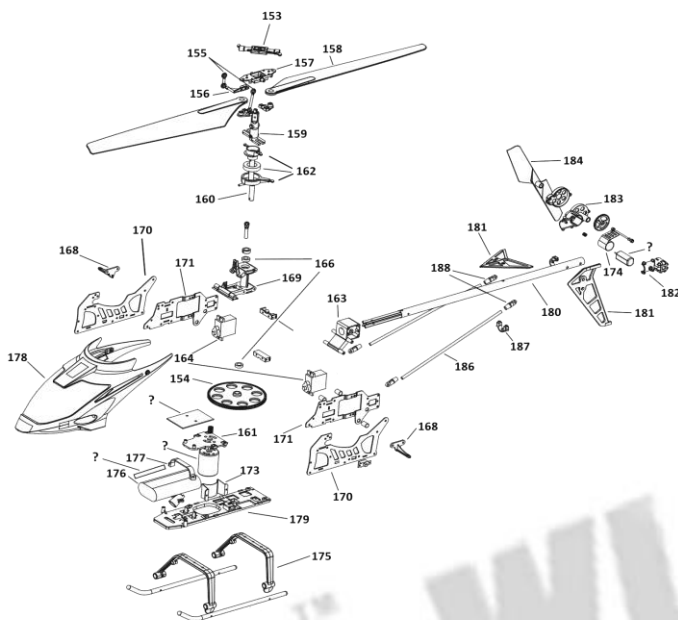

Ref	Description	Quant
152	aluminium cap	1
153	flybar rod	1
154	main gear	1
155	connect buckle	2
156	ball accessories	1
157	blade holder	1
158	blade	1
159	central shaft	1
160	main steel pipe	1
161	fixed motor accessory	1
162	swashplate	1
163	fixed tail pipe accessory	1
164	rudder	2
638	brushless motor	1
166	Bearings	2
639	PCB	1
168	fixed canopy accessory	1
169	main frame	1
170	aluminum sheet(down)	1
171	aluminum sheet(up)	1
172	blade holder	1
173	main motor cooling fin	1
174	tail motor cooling fin	1
175	Landing skid	2
176	battery	1
177	battery spare parts	1
178	Canopy	1
179	baseplate	1
180	tail tube	1
181	fixed horizontal tail accessory	1



Imported by: WLtoys.eu / DroneX BV
Bloemstraat 86HS 1016 LE Amsterdam | www.wltoys.eu |
info@wltoys.eu

Our products comply with the standards and criteria of the European Union and approved by the EC. For your safety, we recommend that you read the entire manual before your first flight.

Congratulations on your purchase of this product from wltoys.eu! WLtoys.eu offers its customers a high quality product. All our products are carefully tested before shipment. If unfortunately a problem persists, contact your dealer or visit www.wltoys.eu. Your dealer can also assist you in getting spare parts in case you need them. We hope you will enjoy your experience with our product.

You can contact us at any time on : www.wltoys.eu | support@wltoys.eu.

You can find instructional videos and buy spare parts on our website www.wltoys.eu.

For technical support contact your reseller.

WARNING:

Non-compliance with safety rules may cause damage, injury and / or dangerous situations.

Warranty

The use of this product is entirely at your own responsibility and at your own risk. Since we have no control beyond this manual on when and how you use our product (both flying and maintenance), we are not responsible for any damages or costs incurred by improper use.

This warranty covers manufacturing and material defects in the context of normal use. We take no responsibility for damage caused indirectly.

The following are excluded from the warranty:

- **Damage caused by the failure to comply with security measures or instructions**
- **Extreme treatment which can not be contained in the usual standards**
- **Overloading the vehicle or external influences**
- **Homemade modifications on the product**
- **The damage caused by the loss of control of the vehicle**
- **Electric defects due to voltage overload or lightning**
- **Normal wear and tear of the device and parts**
- **The costs of transportation, shipping or insurance**
- **The damage caused by the humidity**
- **The damage caused by the loss of the product**
- **After three flights the warranty of brushed engines is void**